



Answer Manitou Sport Fork Rebuild Instructions

Tools:

- Thin standard screw driver
- 5mm hex on ¼ drive socket and long extension
- ¼ drive ratchet

Dissassembly

1. Remove outer fork caps.
2. Use long 5mm allen wrench or 5mm hex bit on ¼" drive socket. .
3. Pull legs down gently to get more room to work with the dust seal and retaining ring.
4. Lift dust seal cover off of flange boss and slide it up inner fork leg.
5. Use a small screwdriver to remove retaining ring.(Figure 1)
6. Pry up dust seal until it is above flange.
7. Pull outer leg assembly down sharply to force upper bushing out of flange.
8. Remove elastomers and washers from allen bolt.
9. Remove flange seal and upper bushing bushing(outer fork leg).

Reassembly

1. Clean all parts thoroughly.
2. Slide retaining ring, dust seal, and upper bushing onto outer legs.
3. Lubricate allen bolt, washers, and elastomers, and bushings with supplied lubricant.

Note: Use the lubricant that is supplied with your kit. Do not use any other lubricant.

4. Place rebound washer and elastomer on 120mm allen bolt and insert allen bolt into inner fork leg.
5. Install lower bushing and assemble elastomers as shown in Figure 2.
6. Grease and install lower bushing onto inner fork leg.
7. Grease ID of outer leg and below upper bushing seat.
8. Install outer legs as a unit onto inner legs. Force the bushings past the flange area.
9. Using a small screwdriver, push the upper bushing down into the flange. Take care not to damage bushings or scratch the inner leg.



Suspension Fork Parts.com

10. Install retaining ring by starting the wide end into the flange groove. Pushing down with a screwdriver rotate to feed ring into the groove. Install and align so that the end gap is oriented straight back.
11. Push outer legs up until compression elastomers touch dropout while pushing the 120mm screws down with allen wrench. Start and tighten the 120mm screw to 30-40 inch-lb (3.5-4.7 N-cm). Do not over tighten, just hand tight using allen wrench is sufficient.
12. Install fork caps.

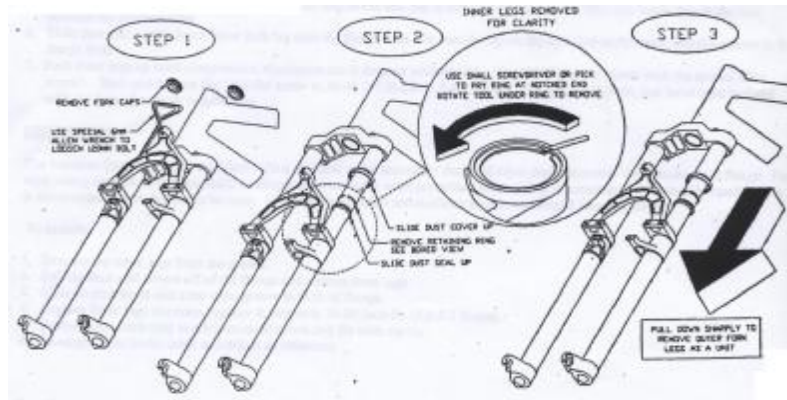

Figure 1

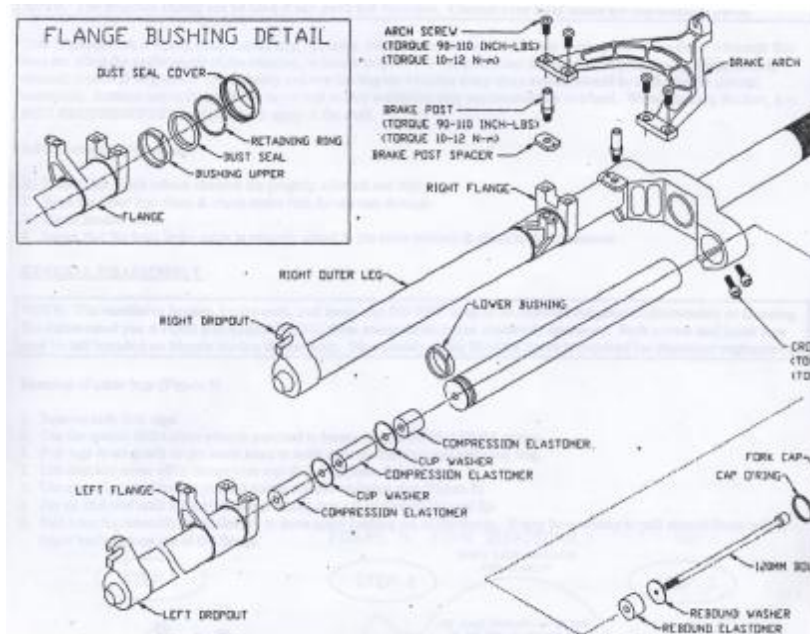

Figure 2

If you have any questions or would like a different ride firmness please email

sales@suspensionforkparts.com

www.suspensionforkparts.com